

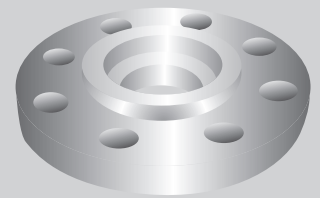

**Large Manufacturer of
Stainless Steel Butt Weld & Forge Fittings**

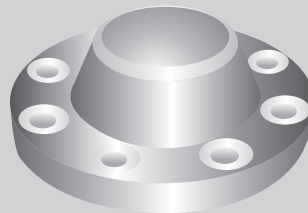
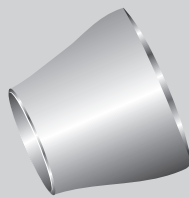
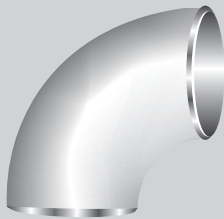

Bhikhsingh (C.E.O.)
09327011561

Karansingh (M.D.)
07874021615



GURUKRUPA

METAL CORPORATION

AN ISO 9001 : 2008 CERTIFIED COMPANY



**GURUKRUPA
INDUSTRIES**



GURUKRUPA METAL CORPORATION



AN ISO 9001 : 2008 CERTIFIED COMPANY

Mob.: 09327011561 / 07874021615 • Ph.: 079-2273 0683 / 6541 7612

COMPANY PROFILE



Introduction

We take pride in introduction ourselves as one of the leading importers, manufacturers, stockists and suppliers of a comprehensive range of premium quality Stainless Steel and Ferrous and Non-Ferrous metal items which are required by your company in all aspects of projects implementation, maintenance, modernization etc. Our offering include stainless steel pipes / tubes, plates, coils, sheets, rods, strips, nuts and bolts. **Gurukrupa Metal Corporation / Gurukrupa Industries** products are known for their high performance, durability and effectiveness.

Established in 1990, the company has always achieved a good growth rate and success, a direct result of our efficient service to trade and industry. We are a proprietorship firm, working under the capable guidance of our proprietor, Mr. Bhikhsingh (C.E.O.) / Karansingh (M.D.) who has vast experience and extensive knowledge of this industry. **Gurukrupa Metal Corporation / Gurukrupa Industries** was established with the objective of always putting customer interest first; that is what we did and what we are still doing today.

Our Product Line :

Stainless Steel : Pipes & Tubes (Seamless / Welded / Fabricated), Sheets, Plates, Rods, Wires, Pipes Fittings and components in AISI 304, 304L, 309, 310, 316, 316L, 317L, 321, 321, 41, 420 & 431 Grades etc. in all dimensions in indigenous and imported make.

Alloys Steel / Carbon Steel :

Pipes and Tubes ((ERW & W / Seamless) as per ASTM A335, P5, P11, P12, P22 and ASTM 106, Gr. B, SA 179, BS-3059 Part I & II, IS-1269

SS/CS/AS Fittings :

Butt-welded / Stock-Welded / Forged and compression type with Ferrules as per ASTM A403, WPS, A182, A105, A234, WPB, WP5, WP11, WP12, WP22, etc. as per project requirements.

We also stock Monel, Nickel, Hastalloy, Inconel 600 / 800, Copper, Brass, Aluminium, Lead, Tin, Zinc and other minor metals in various sizes and shapes.

Over the years, we have gained sufficient experience in this field and received substantial business from reputed concerns in the chemical industry : petrochemical corporations, oil refineries, pharmaceutical companies, pulp and paper mills, cement plants and fertilizer plants. We have also been suppliers to dairies, breweries, sugar mills, nuclear and thermal power stations, engineering concerns as well as projects of national importance. Many of our clients place orders with us on a repeated basis, which speaks volumes of the quality of our products and service.

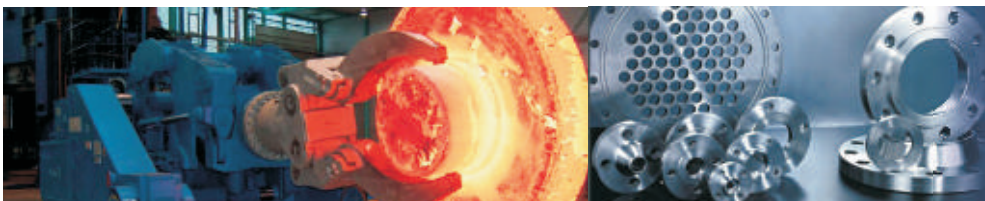

GURUKRUPA
METAL CORPORATION
INDUSTRIES

E-mail : gurukrupametal@yahoo.com / gurukrupametal561@gmail.com • Website : www.gurukrupametal.com



Gurukrupa Industries



AN ISO 9001 : 2008 CERTIFIED COMPANY

Mob.: 09327011561 / 07874021615 • Ph.: 079-2273 0683 / 6541 7612

MANUFACTURING & QUALITY



Quality Assurance



Manufacturing

Gurukrupa Metal Corporation / Gurukrupa Industries is one of the firms engaged in Manufacturing & Processing large variety of Butt-Welding/Forge Pipe Fittings, Flanges, Pipes, in Stainless Steel, Carbob Steel, Alloys Steel Nickel / Super Alloys & Many other Ferrous / Non-Ferrous Metals. The find application in Refining, Petrochemical, Chemical, Oil & Gas, Fertilizers, Pharmaceutical, food & Beverage, Sugar, Paper, Power, Shipbuilding, Aerospace, Engineering, Nuclear, Defense and Research sectors. Our products match National / International standards and meet customer requirements / specification / drawing. Our customers are end users, fabricators and distributors around the world.

We have complete in - house facilities for manufacturing of Butt-weld Fittings & Long Radius and Piggable Bends. These comprise Hot Forging, Cold Forging, bending, Pressing, Welding, Grinding, Gauging, Handling, Hydraulic Testing, Heat Treatment, Annealing, Shot Blasting, Pickling & Passivation, Anti-Rust Coating & Packing.

Each manufacturing phase, from forging to welding, machining to testing is carried out with a vasty array of modern equipment and machinery. We exercise control over every bit of materials throughout the manufacturing process, thanks to our rigorous QA & QC procedures. We also engage the services of external chemical and mechanical laboratories well equipped to perform both destructive and non-destructive examinations. We provide Laboratory Test Certificates, Government / Lloyds approved Laboratory test certificates, Third party inspection certificates and Guarantee / Warranty Certificate for the supplies.

The mission of **Gurukrupa Metal Corporation / Gurukrupa Industries** is to provide the best customer service by supplying products manufactured with the latest technology, repecting delivery time lines, monitoring work progress and satisfying urgent customer requirements by leveraging our vast inventory of raw material, semi-finished and finished products.

We wish to always be a reference for reliability, competence and service in the industry. We build lasting relationship with customer and contribute to their success, because we know that their success is ours as well.

In recent years, the need for operating safety requirements for pipe systems has been rising exponentially. To meet this growing volume of requirements, **Gurukrupa Metal Corporation / Gurukrupa Industries** has done pioneering work in the field of development & Manufacture of seamless and welded fittings.

The advanced technology, supported by the superior design and construction of our manufacturing equipment, enables us to not only meet the requirements of internationally accepted manufacturing standards, but also cope with the growing demand for special fittings. Our heat treatment facilities are quipped with high precision temperature control, which enables optimal djustment of materials properties.

Our quality assurance system is documented in an approved quality assurance manual and covers all production process. We exercise rigorous control over dimensions and mechanical properties-starring from the raw materials, through all the production phase, to laboratory test on the finished product-in order maintain the high quality levels of **Gurukrupa Metal Corporation / Gurukrupa Industries** products.



DIMENSION IN M.M. OF BUTT WELDING FITTINGS TO ANSI B 16.9

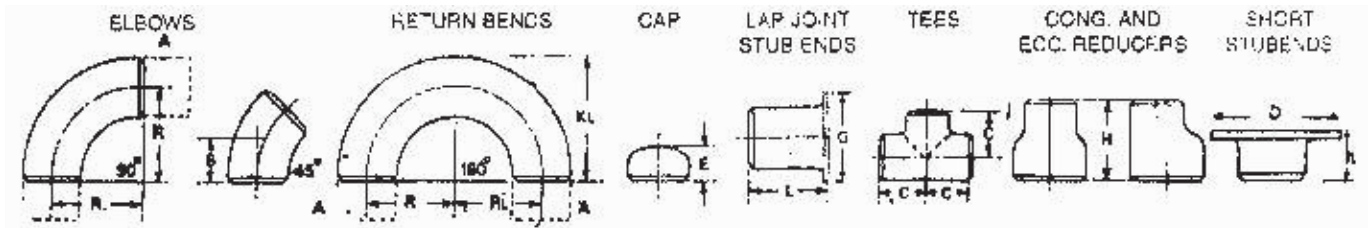

NOM BORE	PIPE OD	WALL THICKNESS				RADIUS				R	B	C	E	G	L		H	D	H
		SS	10S	40S	80S	1D	1.5D	2D	3D						SHORT	LONG			
1/2	21.34	1.66	2.11	2.77	3.73	12.7	19.05	25.4	38.1	15.9	25.4	25.4	34.9	50.8	76.2	38.1	45	8	
3/4	26.67	1.65	2.11	2.87	3.91	19.05	28.57	38.10	57.15	11.1	28.6	25.4	42.8	50.8	76.2	38.1	54	8	
1	33.40	1.65	2.77	3.38	4.55	25.4	38.1	50.8	76.2	22.2	38.1	38.1	50.8	50.8	101.6	50.8	64	10	
1 1/4	42.16	1.65	2.77	3.56	4.85	31.75	47.6	63.5	95.25	25.0	47.6	38.1	63.5	50.8	101.6	50.8	74	12	
1 1/2	48.26	1.65	2.77	3.68	5.08	38.1	57.15	76.2	114.3	28.6	57.2	38.1	73.0	50.8	101.6	63.5	84	12	
2	60.32	1.65	2.77	3.91	5.54	50.8	76.2	101.6	152.4	34.0	63.5	38.1	92.0	63.5	152.4	76.2	102	14	
2 1/2	73.02	2.11	3.05	5.16	7.01	63.5	95.25	127.0	190.5	44.0	76.2	38.1	104.8	63.5	152.4	88.9	122	16	
3	88.90	2.11	3.05	5.49	7.62	76.2	114.30	152.4	228.6	50.8	85.7	50.8	127.0	63.5	152.4	88.9	138	18	
3 1/2	101.60	2.11	3.05	5.74	8.08	88.9	113.35	177.8	266.7	57.2	95.3	63.5	139.7	76.2	152.4	101.6	148	18	
4	114.30	2.11	3.05	6.02	8.56	101.6	152.4	203.2	304.8	63.5	104.8	63.5	157.2	76.2	152.4	101.6	158	20	
5	141.30	2.77	3.40	6.55	9.52	127.0	190.5	254.0	381.0	79.4	123.8	76.2	185.7	76.2	203.2	127.0	188	25	
6	168.28	2.77	3.40	7.11	10.97	152.4	228.6	304.8	457.2	95.3	142.8	88.9	215.9	88.9	203.2	139.7	212	25	
8	219.08	2.77	3.76	8.18	12.7	203.2	304.8	406.4	609.6	127.0	177.8	101.6	270.0	101.6	203.2	152.4	270	30	
10	273.05	3.40	4.19	9.27	12.7	254.0	381.0	508.0	762.0	158.7	215.9	127.0	324.0	127.0	254.0	177.8	325	30	
12	323.85	3.96	4.57	9.52	17.45	304.8	457.2	609.6	914.4	190.5	254.0	152.4	381.0	152.4	254.0	203.2	380	35	
14	355.60	3.96	4.78	11.13	15.0	355.6	533.4	711.2	1066.8	222.2	280.0	165.1	412.8	152.4	305.0	330.2	415	40	
16	406.40	4.19	4.78	12.7	21.45	406.4	609.6	812.8	1219.2	254.0	304.8	177.8	470.0	152.4	305.0	355.6	470	40	
18	457.20	4.19	4.78	14.27	23.80	457.2	685.8	914.4	1371.6	385.7	343.0	203.2	533.4	152.4	305.0	381.0	535	40	
20	508.00	4.78	5.54	15.09	26.19	508.00	762.0	101.6	1524.0	317.6	381.0	288.6	584.2	152.4	305.0	508.0	585	40	
22	588.8	4.78	6.35	15.88	28.57	558.8	838.2	1117.6	1676.4	343	419	254	641.4	152.4	305	508	642	40	
24	609.6	5.54	6.35	17.48	30.94	609.6	914.4	1219.2	1828.8	381	432	266.7	692.2	152.4	305	508	693	40	

STANDARDS : All dimensions are in mm and confirm to ANSI B 16.9 and M.S.S. P-43 where applicable Dimensional tolerances are in accordance with ANSI B 16.9 and M.S.S. SP-43 where applicable.

RADIUS : Radius of short Elbows is 1 times nominal pipe diameter, Radius of Long Radius Elbows is 1 1/2 times nominal pipe diameter.

MATERIAL OF CONSTRUCTION : S. S. 304/304L/316/316L/317/321 Nickel Alloys.



SOCKET WELD FITTING TO ANSI B-16.11

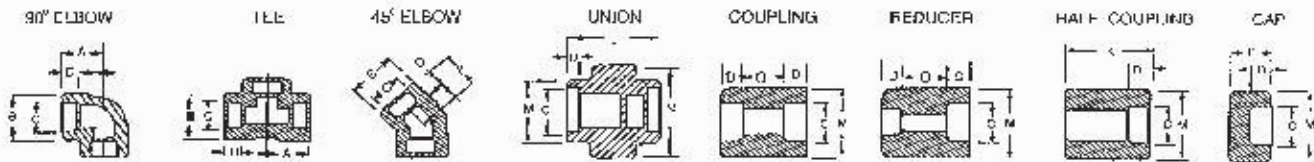

NOM BORE	PIPE O.D.	3000 LBS.									COMMON FACTORS				6000 LBS.				
		A max.	B max.	K	J	L	M	N	P	Q	C min.	D min.	O min.	O max.	A	B	M	K	N
1/8"	10.3	22	18.5	26	16	40	17.3	32	15	10	10.7	10	5	8	22	22	20	25	16
1/4"	13.7	22	22	26	18	43	21.2	32	15	10	14.1	10	5	8	27	25	24	25	51
3/8"	17.2	25	25	26	19	48	25.4	36	16.5	10	17.6	10	3	9	27	28	28	26	60
1/2"	21.3	27	32	30	21	51	31	41	16.5	10	21.7	10	5	13	31	34	34	31	72
3/4"	26.7	34	38	36	24	57	37	50	19.5	12	27	13	5	13	37	42	41	35	80
1"	33.4	37	46	40	25	64	45.2	60	22.5	13	33.8	13	9	17	42	50	50	40	94
1 1/4"	42.2	47	56	40	29	70	55	70	22.5	13	42.6	13	9	17	47	59	58	41	100
1 1/2"	48.3	47	62	40	30	79	61.4	78	24	13	48.7	13	9	17	53	67	66	43	122
2"	60.3	56	75	52	37	89	75	95	29	13	61.2	16	15	23	59	84	83	55	
2 1/2"	73.02	60	92	52	48	114	91.3	125	32	16	73.8	16	14	24		102		56	
3"	89.00	76	110	52	51	127	108.8	140	35	16	89.8	16	14	24		121		58	
4"	114.50	88	137	58		150	136.9		42	19	115.5	19	14	24		152		64	

FORGED SCREWED FITTING TO ANSI B-16.11 3000/6000 LBS.

THREADED TO ASA B 2.1

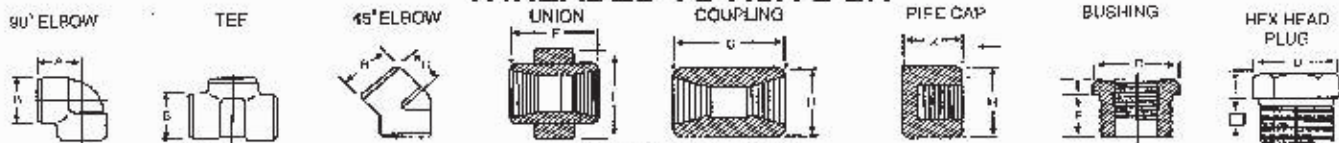

(DIMENSIONS IN MM)

NOM BORE	PIPE O.D.	3000 LBS.									COMMON FACTORS				6000 LBS.				
		A	B	C	G	H	K	D	E	F	I	J	L	A	B	C	G	H	K
1/8"	10.3	21	22	17	32	16	19	11	10	40	-	6	-	25	25	19	32	22	-
1/4"	13.7	25	25	19	35	19	25	16	11	43	3	6	32	29	33	22	35	25	27
3/8"	17.2	29	33	22	38	22	25	17.5	13	48	4	8	38	33	38	25	38	32	27
1/2"	21.3	33	38	25	48	29	32	22	15	51	5	8	46	38	46	29	48	38	33
3/4"	26.7	38	46	29	51	35	37	27	16	57	6	10	51	44	56	33	51	44	38
1"	33.4	44	56	33	60	44	41	35	19	64	6	10	60	51	62	35	60	57	43
1 1/4"	42.2	51	62	35	67	57	44	44.5	21	70	7	14	72	60	75	43	67	64	64
1 1/2"	48.3	60	75	43	79	64	44	51	21	79	8	16	80	64	84	44	79	76	48
2"	60.3	64	84	45	86	76	48	63.5	22	88	9	17	94	83	102	52	86	92	51
2 1/2"	73.02	83	102	52	92	92	60	76	27	118	10	21	122	95	121	64	92	108	64
3"	89.00	95	121	64	108	108	65	89	29	121	10	25	140	105	146	79	108	127	68
4"	114.5	114	152	79	121	140	68	117.5	32	150	13	25	180	114	152	79	121	159	75

DIMENSIONS AND OTHERS SPECIFICATIONS AS PER CUSTOMERS REQUIREMENTS ARE AVAILABLE ON REQUEST

DIMENSION OF FLANGES TO ASME / ANSI B 16.5

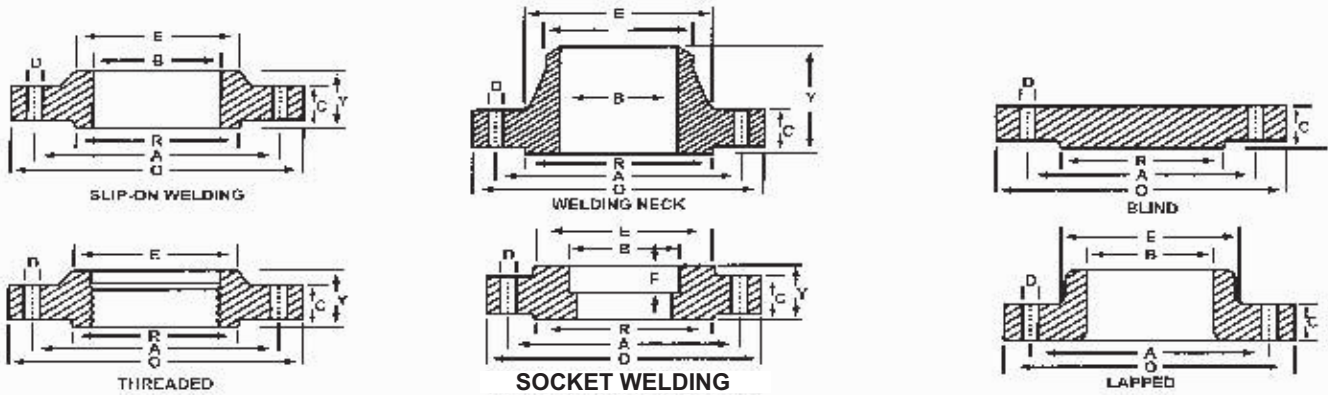

DIMENSIONS OF CLASS 150 FLANGES (ASME / ANSI B16.5) (in mm)													
Nominal Size Inch	Flange Dia O	Dia of Bolt Circle A	Dia of Bolt Holes D	No. of HOLES	Thk of Flagne C	Dia of Hub E	Length through Hub			Dia of Bore		Dia of R/F R	Depth of Socket F
							S/O&S/W Y	W/N Y	L/J Y	S/O&S/W B	L/J B		
1/2	88.9	60.4	15.9	4	11.2	30.2	14.2	45.9	15.7	22.3	22.8	35.0	9.6
3/4	98.5	69.8	15.9	4	12.7	38.1	14.2	50.8	15.7	27.6	28.2	42.9	11.1
1	107.9	79.2	15.9	4	14.2	49.2	15.7	53.8	17.5	34.5	35.0	50.8	12.7
1 1/4	117.3	88.9	15.9	4	15.7	58.6	19.0	55.6	20.5	43.1	43.6	63.5	14.2
1 1/2	127.0	98.5	15.9	4	17.5	65.0	20.5	60.4	22.3	49.5	50.0	73.1	15.7
2	152.4	120.6	19.0	4	19.0	77.7	23.8	61.9	25.4	61.9	62.4	91.9	17.5
2 1/2	177.8	139.7	19.0	4	22.3	90.4	26.9	68.3	28.4	74.6	75.4	104.6	19.0
3	190.5	152.4	19.0	4	23.9	107.9	28.4	68.3	30.2	90.6	91.4	127.0	20.5
4	228.6	190.5	19.0	8	23.9	134.8	31.7	74.6	33.2	116.0	116.8	157.2	
5	254.0	215.9	22.2	8	23.9	163.5	35.0	87.3	36.5	143.7	144.5	185.6	
6	279.4	241.3	22.2	8	25.4	192.0	38.1	87.3	39.6	170.6	171.4	215.9	
8	342.9	298.4	22.2	8	28.4	246.1	42.9	100.0	44.4	221.4	222.2	269.7	
10	406.4	361.9	25.4	12	30.2	304.8	47.7	100.0	49.2	276.3	277.3	323.8	
12	482.6	431.8	25.4	12	31.8	365.2	53.8	112.7	55.6	327.1	328.1	381.0	
14	533.4	476.2	28.6	12	35.0	400.0	55.6	125.4	79.2	359.1	360.1	412.7	
16	596.9	539.7	28.6	16	36.6	457.2	61.9	125.4	87.3	410.4	411.2	469.9	
18	635.0	577.8	31.7	16	39.6	504.9	66.5	138.8	96.7	461.7	462.2	533.4	
20	698.5	635.0	31.7	20	42.9	558.8	71.3	142.7	103.1	513.0	514.3	584.2	
24	812.8	749.3	34.9	20	47.8	663.4	81.0	150.8	111.2	615.9	615.9	692.1	

DIMENSIONS OF CLASS 300 FLANGES (ASME / ANSI B16.5) (in mm)													
Nominal Size Inch	Flange Dia O	Dia of Bolt Circle A	Dia of Bolt Holes D	No. of HOLES	Thk of Flagne C	Dia of Hub E	Length through Hub			Dia of Bore		Dia of R/F R	Depth of Socket F
							S/O&S/W Y	W/N Y	L/J Y	S/O&S/W B	L/J B		
1/2	95.2	66.5	15.9	4	14.2	38.1	20.5	50.8	22.3	22.3	22.8	35.0	9.6
3/4	117.3	82.5	19.0	4	15.7	47.7	23.8	55.6	25.4	27.6	28.2	42.9	11.1
1	123.9	88.9	19.0	4	17.5	53.8	25.4	60.4	26.9	34.5	35.0	50.8	12.7
1 1/4	133.3	98.5	19.0	4	19.0	63.5	25.4	63.5	26.9	43.1	43.6	63.5	14.2
1 1/2	155.4	114.3	22.2	4	20.6	69.8	28.4	66.5	30.2	49.5	50.0	73.1	15.7
2	165.1	127.0	19.0	8	22.4	84.0	33.2	69.8	33.2	61.9	62.4	91.9	17.5
2 1/2	190.5	149.3	22.2	8	25.4	100.0	38.1	76.2	38.1	74.6	75.4	104.6	19.0
3	209.5	168.1	22.2	8	28.4	117.3	42.9	79.2	42.9	90.6	91.4	127.0	20.5
4	254.0	200.1	22.2	8	31.8	146.0	47.7	85.8	47.7	116.0	116.8	157.2	
5	279.4	234.9	22.2	8	35.0	177.8	50.8	98.5	50.8	143.7	144.5	185.6	
6	317.5	269.7	22.2	12	36.6	206.2	52.3	98.5	52.3	170.6	171.4	215.9	
8	381.0	330.2	25.4	12	41.1	260.3	61.9	111.2	61.9	221.4	222.2	269.7	
10	444.5	387.3	28.6	16	47.8	320.5	66.5	117.3	95.2	276.3	277.3	323.8	
12	520.7	450.8	31.7	16	50.8	374.6	73.1	130.0	101.6	327.1	328.1	381.0	
14	584.2	514.3	31.7	20	53.8	425.4	76.2	142.2	111.2	359.1	360.1	412.7	
16	647.7	571.5	34.9	20	57.2	482.6	82.5	146.0	120.6	410.4	411.2	469.9	
18	711.2	628.6	34.9	24	60.5	533.4	88.9	158.7	130.0	461.7	462.2	533.4	
20	774.7	685.8	34.9	24	63.5	587.2	95.2	162.0	139.7	513.0	514.3	584.2	
24	914.4	812.8	41.3	24	69.9	701.5	106.4	168.1	152.4	615.9	615.9	692.1	

General Note : All Dimensions are in millimeters.

1) Thickness 'C' is inclusive Raised Face Thickness of 1.6 MM. For Class 150 and Class 300.



DIMENSION OF FLANGES TO ASME / ANSI B 16.5

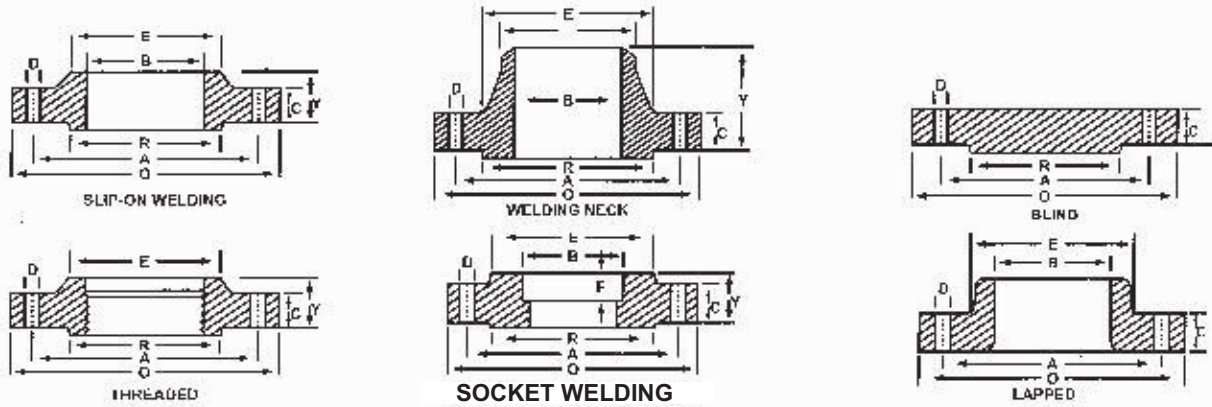

DIMENSIONS OF CLASS 600 FLANGES (ASME / ANSI B16.5)

(in mm)

Nominal Size Inch	Flange Dia O	Dia of Bolt Circle A	Dia of Bolt Holes D	No. of HOLES	Thk of Flagne C	Dia of Hub E	Length through Hub			Dia of Bore		Dia of R/F R	Depth of Socket F
							S/O&S/W	W/N	L/J	S/O&S/W	L/J		
							Y	Y	Y	B	B		
1/2	95.2	66.5	15.9	4	14.2	38.1	22.3	52.3	22.2	22.3	22.8	35.0	9.6
3/4	117.3	82.5	19.0	4	15.7	47.7	25.4	57.1	25.4	27.6	28.2	42.9	11.1
1	123.9	88.9	19.0	4	17.5	53.8	26.9	61.9	26.9	34.5	35.0	50.8	12.7
1 1/4	155.4	98.5	19.0	4	20.6	63.5	28.4	66.5	28.4	43.1	43.6	63.5	14.2
1 1/2	165.1	114.3	22.2	4	22.3	69.8	31.7	69.8	31.7	49.5	50.0	73.1	15.7
2	190.5	127.0	19.0	8	25.4	84.0	36.5	73.1	36.5	61.9	62.4	91.9	17.5
2 1/2	209.5	149.3	22.2	8	28.4	100.0	41.1	79.2	41.1	74.6	75.4	104.6	19.0
3	273.0	168.1	22.2	8	31.8	117.3	45.9	82.5	45.9	90.6	91.4	127.0	20.5
4	330.2	215.9	25.4	8	38.1	152.4	53.8	101.6	53.8	116.0	116.8	157.2	-
5	355.6	266.7	28.6	8	44.4	188.9	60.4	114.3	60.4	143.7	114.5	185.6	-
6	419.1	292.1	28.6	12	47.7	222.2	66.5	117.3	66.5	170.6	171.4	215.9	-
8	508.0	349.2	31.7	12	55.6	273.0	76.2	133.3	76.2	221.4	222.2	269.7	-
10	558.8	431.8	34.9	16	63.5	342.9	85.8	152.4	111.2	276.3	277.3	323.8	-
12	603.2	488.9	34.9	20	66.5	400.0	91.9	155.4	117.3	327.1	328.1	381.0	-
14	685.8	527.0	38.1	20	69.9	431.8	93.7	165.1	127.0	359.1	360.1	412.7	-
16	503.2	603.2	41.3	20	76.2	495.3	106.4	177.8	139.7	410.4	411.2	469.9	-
18	742.9	654.0	44.4	20	82.6	546.1	117.3	184.1	152.4	461.7	462.2	533.4	-
20	812.8	723.9	44.4	24	88.9	609.6	127.0	190.5	165.1	513.0	514.3	584.2	-
24	939.8	838.2	50.8	24	101.6	717.5	139.7	203.2	184.1	615.9	615.9	692.1	-

DIMENSIONS OF CLASS 900 FLANGES (ASME / ANSI B16.5)

Nominal Size Inch	Flange Dia O	Dia of Bolt Circle A	Dia of Bolt Holes D	No. of HOLES	Thk of Flagne C	Dia of Hub E	Length through Hub			Dia of Bore		Dia of R/F R	Depth of Socket F
							S/O&S/W	W/N	L/J	S/O&S/W	L/J		
							Y	Y	Y	B	B		
1/2	120.6	82.5	22.2	4	22.4	38.1	31.7	60.4	31.7	22.3	22.8	35.0	-
3/4	130.0	88.9	22.2	4	25.4	44.4	35.0	69.8	35.0	27.6	28.2	42.9	-
1	149.3	101.6	25.4	4	28.4	52.3	41.1	73.1	41.1	34.5	35.0	50.8	-
1 1/4	158.7	111.2	25.4	4	28.4	63.5	41.1	73.1	41.1	43.1	43.6	63.5	-
1 1/2	177.8	123.9	28.6	4	31.8	69.8	44.4	82.5	44.4	49.5	50.0	73.1	-
2	215.9	165.1	25.4	8	38.1	104.6	57.1	101.6	57.1	61.9	62.4	91.9	-
2 1/2	244.3	190.5	28.6	8	41.1	123.9	63.5	104.6	63.5	74.6	75.4	104.6	-
3	241.3	190.5	25.4	8	38.1	127.0	53.8	101.6	53.8	90.6	91.4	127.0	-
4	292.1	234.9	31.7	8	44.5	158.7	69.8	114.3	69.8	116.0	116.8	157.2	-
5	349.2	279.4	34.9	8	50.8	190.5	79.2	127.0	79.2	143.7	144.5	185.6	-
6	381.0	317.5	31.7	12	55.6	234.9	85.8	139.7	85.8	170.6	171.4	215.9	-
8	469.9	393.7	38.1	12	63.5	298.4	101.6	162.0	114.3	221.4	222.2	269.7	-
10	546.1	469.9	38.1	16	69.8	368.3	107.9	184.1	127.0	276.3	277.3	323.8	-
12	609.6	533.4	38.1	20	79.2	419.1	117.3	200.1	142.7	327.1	328.1	381.0	-

General Note : All Dimensions are in millimeters.

1) Thickness 'C' is Exclusive of Raised Face Thickness of 6.35 MM. For Class 600 and Class 900.

DIMENSION OF FLANGES TO ASME / ANSI B 16.5

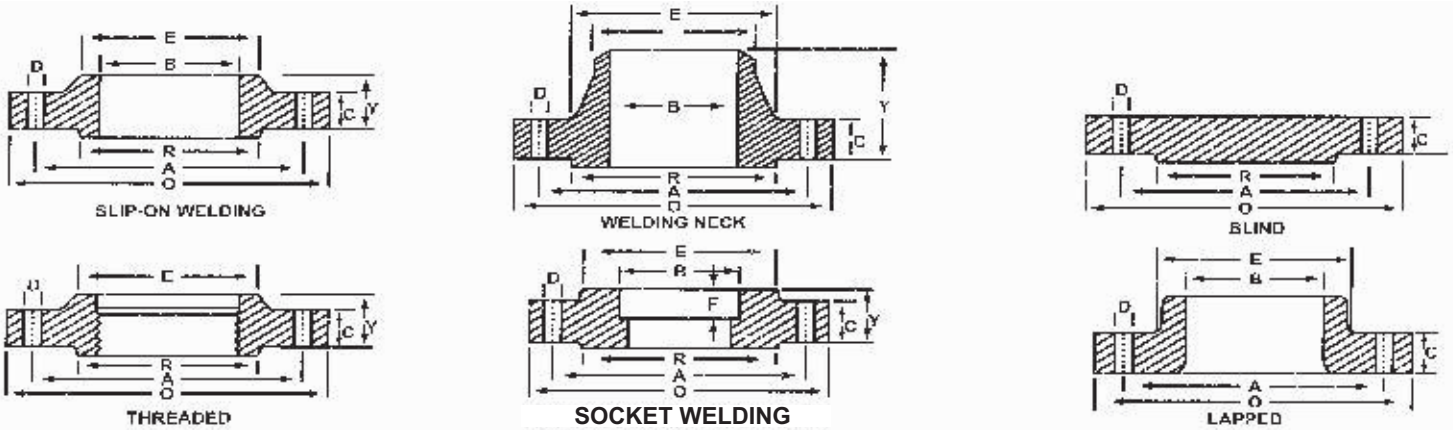

DIMENSIONS OF CLASS 1500 FLANGES (ASME / ANSI B16.5)

(in mm)

Nominal Size Inch	Flange Dia O	Dia of Bolt Circle A	Dia of Bolt Holes D	No. of HOLES	Thk of Flange C	Dia of Hub E	Length through Hub			Dia of Bore		Dia of R/F R	Depth of Socket F
							S/O&S/W	W/N	L/J	S/O&S/W	L/J		
							Y	Y	Y	B	B		
1/2	120.6	82.5	22.2	4	22.4	38.1	31.7	31.7	31.7	22.3	22.8	35.0	-
3/4	130.0	88.9	22.2	4	25.4	44.4	35.0	35.0	35.0	27.6	28.2	42.9	-
1	149.3	101.6	25.4	4	28.4	52.3	41.1	41.1	41.1	34.5	35.0	50.8	-
1 1/4	158.7	111.2	25.4	4	28.4	63.5	41.1	41.1	41.1	43.1	43.6	63.5	-
1 1/2	177.8	123.9	28.6	4	31.8	69.8	44.4	44.4	44.4	49.5	50.0	73.1	-
2	215.9	165.1	25.4	8	38.1	104.6	57.1	57.1	57.1	61.9	62.4	91.9	-
2 1/2	244.3	190.5	28.6	8	41.1	123.9	63.5	63.5	63.5	74.6	75.4	104.6	-
3	266.7	203.2	31.7	8	47.8	133.3		117.3	73.1	90.6	91.4	127.0	-
4	311.1	241.3	34.9	8	53.8	162.0		123.9	90.4	116.0	116.8	157.2	-
5	374.6	292.1	41.2	8	73.2	196.8		155.4	104.6	143.7	144.5	185.6	-
6	393.7	317.5	38.1	12	82.6	228.6		171.4	119.1	170.6	171.4	215.9	-
8	482.6	393.7	44.4	12	91.9	292.1		212.8	142.7	221.4	222.2	269.7	-
10	584.2	482.6	50.8	12	108.0	368.3		254.0	177.8	276.3	277.3	323.8	-
12	673.1	571.5	54.0	16	124.0	450.8		282.4	218.9	327.1	328.1	381.0	-

DIMENSIONS OF CLASS 2500 FLANGES (ASME / ANSI B16.5)

(in mm)

Nominal Size Inch	Flange Dia O	Dia of Bolt Circle A	Dia of Bolt Holes D	No. of HOLES	Thk of Flange C	Dia of Hub E	Length through Hub			Dia of Bore		Dia of R/F R	Depth of Socket F
							S/O&S/W	W/N	L/J	S/O&S/W	L/J		
							Y	Y	Y	B	B		
1/2	133.3	88.9	22.2	4	30.2	42.9	39.6	73.1	39.6	22.3	22.8	35.0	-
3/4	139.7	95.2	22.2	4	31.7	50.8	42.9	79.2	42.9	27.6	28.2	42.9	-
1	158.7	107.9	25.4	4	35.0	57.1	47.7	88.9	47.7	34.5	35.0	50.8	-
1 1/4	184.1	130.0	28.6	4	38.1	73.2	52.3	95.2	52.3	43.1	43.6	63.5	-
1 1/2	203.2	146.0	31.7	4	44.5	79.4	60.4	111.2	60.4	49.5	50.0	73.1	-
2	234.9	171.4	28.6	8	50.8	95.2	69.3	127.0	69.3	61.9	62.4	91.9	-
2 1/2	266.7	196.8	31.7	8	57.1	114.3	79.2	142.7	79.2	74.6	75.4	104.6	-
3	304.8	228.6	34.9	8	66.5	133.3	92.0	168.1	92.1	90.6	91.4	127.0	-
4	355.6	273.0	41.3	8	76.2	165.1	107.9	190.5	107.9	116.0	116.8	157.2	-
5	419.1	323.8	47.6	8	92.0	203.2	130.0	128.6	130.0	143.7	144.5	185.6	-
6	482.6	368.3	54.0	8	107.9	234.9	152.4	273.0	152.4	170.6	171.4	215.9	-
8	552.4	438.1	54.0	12	127.0	304.8	177.8	317.5	177.8	221.4	222.2	269.7	-
10	673.1	539.7	66.7	12	165.1	374.6	228.6	419.1	228.6	276.3	277.3	323.8	-
12	762.0	619.2	73.0	12	184.1	441.3	254.0	463.5	254.0	327.1	328.1	381.0	-

General Note : All Dimensions are in millimeters.

1) Thickness 'C' is Exclusive of Raised Face Thickness of 6.35 MM. For Class 1500 and Class 2500.



DIMENSION OF PIPE FLANGES AS PER TABLE BS-10

Table D : For Working Steam Pressure upto 50 lbs per sq. inch

Nominal Pipe size	O.D. of Pipe	Dia. of Flange	Dia. of Bolt Circle	No. of Bolt	Dia. of Bolt	Thickness
1/2"	21.3	95.3	65.7	4	12.7	4.8
3/4"	26.7	101.6	73.0	4	12.7	4.8
1"	33.4	114.3	82.6	4	12.7	4.8
1 1/4"	42.2	120.7	87.6	4	12.7	6.4
1 1/2"	48.3	133.4	98.4	4	12.7	6.4
2"	60.3	152.4	114.3	4	15.9	7.9
2 1/2"	73.0	165.1	127.0	4	15.9	7.9
3"	88.9	184.2	146.1	4	15.9	9.5
3 1/2"	101.6	203.2	165.1	4	15.9	9.5
4"	114.3	215.9	177.8	4	15.9	9.5
5"	141.3	254.0	209.6	8	15.9	12.7
6"	168.3	279.4	228.6	8	15.9	12.7
7"	190.5	304.8	260.4	8	15.9	12.7
8"	219.1	336.6	292.1	8	15.9	12.7
9"	244.5	368.3	323.9	8	15.9	15.9
10"	273.0	406.4	355.6	8	19.1	15.9
12"	323.9	457.2	406.4	12	19.1	15.9
14"	355.6	527.1	469.9	12	22.2	19.1
16"	406.4	577.9	520.7	12	22.2	19.1
18"	457.2	641.4	584.2	12	22.2	22.2
20"	508.0	704.9	641.4	16	22.5	25.4
24"	609.6	825.5	755.7	16	25.4	28.6

Table E : For Working Steam Pressure 50 lbs upto 100 lbs per sq. inch

Nominal Pipe size	Dia. of Flange	Dia. of Bolt Circle	No. of Bolt	Dia. of Bolt	Thickness
1/2"	95.3	66.7	4	12.7	6.4
3/4"	101.6	73.0	4	12.7	6.4
1"	114.3	82.6	4	12.7	7.1
1 1/4"	120.7	87.3	4	12.7	7.9
1 1/2"	133.4	98.4	4	12.7	8.7
2"	152.4	114.3	4	15.9	9.5
2 1/2"	165.1	127.0	4	15.9	10.3
3"	184.2	146.1	4	15.9	11.1
3 1/2"	203.2	165.1	8	15.9	11.9
4"	215.9	177.8	8	15.9	12.7
5"	254.0	209.6	8	15.9	14.3
6"	279.4	228.6	8	19.1	17.5
7"	304.8	260.4	8	19.1	19.1
8"	336.6	292.1	8	19.1	19.1
9"	368.3	323.9	12	19.1	20.6
10"	406.4	355.6	12	19.1	22.2
12"	457.2	406.4	12	22.2	25.4
14"	527.2	469.9	12	22.2	25.4
16"	577.9	520.7	12	22.2	25.4
18"	641.4	584.2	16	22.2	28.6
20"	704.9	647.4	16	22.2	31.8
24"	825.5	755.7	16	25.4	30.1

Table F : For Working Steam Pressure above 100 lbs and upto 150 lbs per sq. inch

Nominal Pipe size	O.D. of Pipe	Dia. of Flange	Dia. of Bolt Circle	No. of Bolt	Dia. of Bolt	Thickness
1/2"	21.3	95.3	66.7	4	12.7	9.5
3/4"	26.7	101.6	73.0	4	12.7	9.5
1"	33.4	120.7	87.3	4	15.9	9.5
1 1/4"	42.2	133.4	98.4	4	15.9	12.7
1 1/2"	48.3	139.7	104.8	4	15.9	12.7
2"	60.3	165.1	127.0	4	15.9	15.9
2 1/2"	73.0	184.2	146.1	8	15.9	15.9
3"	88.9	203.2	165.1	8	15.9	15.9
3 1/2"	101.6	215.9	177.8	8	15.9	19.1
4"	114.3	228.6	190.5	8	15.9	19.1
5"	141.3	279.4	235.0	8	19.1	22.2
6"	168.3	304.8	260.4	12	19.1	22.2
7"	190.5	336.6	292.1	12	19.1	22.2
8"	219.1	368.3	323.9	12	19.1	25.4
9"	244.5	406.4	355.6	12	22.2	25.4
10"	273.0	431.8	381.0	12	22.2	25.4
12"	323.9	489.0	438.2	16	22.2	28.6
14"	355.6	552.5	495.3	16	25.4	31.8
16"	406.4	609.6	552.5	20	25.4	31.8
18"	457.2	673.1	609.6	20	28.6	34.9
20"	508.0	736.6	673.1	24	28.6	38.1
24"	609.6	850.9	781.1	24	31.8	41.3

Table H : For Working Steam Pressure above 150 lbs and upto 250 lbs per sq. inch

Nominal Pipe size	Dia. of Flange	Dia. of Bolt Circle	No. of Bolt	Dia. of Bolt	Thickness
1/2"	114.3	82.6	4	15.9	12.7
3/4"	114.6	82.6	4	15.9	12.7
1"	120.78	87.3	4	15.9	14.3
1 1/4"	133.4	98.4	4	15.9	17.5
1 1/2"	139.7	104.8	4	15.9	17.5
2"	165.1	127.0	4	15.9	19.1
2 1/2"	184.2	146.1	8	15.9	19.1
3"	203.2	165.1	8	15.9	22.2
3 1/2"	215.9	177.8	8	15.9	22.2
4"	228.6	190.5	8	15.9	25.4
5"	279.4	235.0	8	19.1	28.6
6"	304.8	260.4	12	19.1	28.6
7"	336.6	292.1	12	19.1	31.8
8"	368.3	323.9	12	19.1	31.8
9"	406.4	355.6	12	22.2	34.9
10"	431.8	381.0	12	22.2	34.9
12"	489.0	438.2	16	22.2	38.1
14"	552.5	495.3	16	25.4	41.3
16"	609.6	552.5	20	25.4	44.5
18"	673.1	609.6	20	28.6	47.6
20"	736.6	673.1	24	28.6	50.8
24"	850.9	781.1	25	31.8	57.2

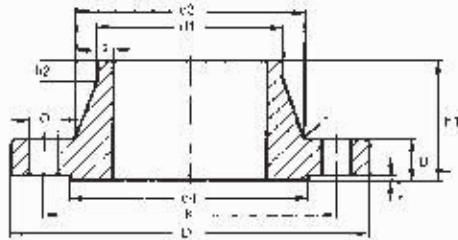

WNRF

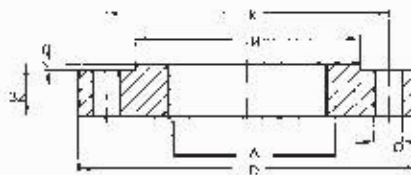

SORF

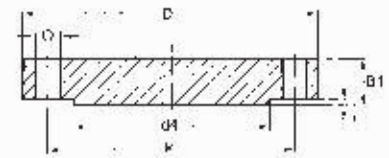

BLRF

DIMENSIONS IN MM OF PN 10 FLANGES

SIZE	D	D1	A	B	B1	B2	k	h1	d3	s	r	h2	d4	f	No	Size	O
	O.D	HK O.D	ID 2573	thk 2632	thk 2627	thk 2576	PCD	wnrf		Nr.hk			RF 2632	RF-1HK	of Holes	BOI I	Hole
			SORF	WNRF	BLRF	SORF		height					WNRF				DA
10	90	17.2	17.7	14	14	14	60	35	28	1.8	4	6	40	2	4	M 12	14
15	95	21.3	22	14	14	14	65	35	32	2	4	6	45	2	4	M 12	14
20	105	26.9	27.6	16	16	16	75	38	40	2.3	4	6	58	2	4	M 12	14
25	115	33.7	34.4	16	16	16	85	38	45	2.6	4	6	68	2	4	M 12	14
32	140	42.4	43.1	16	16	16	100	40	56	2.6	6	6	78	2	4	M 16	18
40	150	48.3	49	16	16	16	110	42	64	2.6	6	7	88	3	4	M 16	18
50	165	60.3	61.1	18	18	18	125	45	75	2.9	6	8	102	3	4	M 16	18
65	185	76.1	77.1	18	18	18	145	45	90	2.9	6	10	122	3	4	M 16	18
80	200	88.9	90.3	20	20	20	160	50	105	3.2	8	10	138	3	8	M 16	18
100	220	114.3	115.9	20	20	20	180	52	131	3.6	8	12	158	3	8	M 16	18
125	250	139.5	141.6	22	22	22	210	55	156	4	8	12	188	3	8	M 16	18
150	285	168.3	170.5	22	22	22	240	55	184	4.5	10	12	212	3	8	M 20	22
175	315	193.7	196.1	24	24	24	270	60	210	5.4	10	12	242	3	8	M 20	22
200	340	219.1	221.8	24	24	24	295	62	235	5.9	10	16	268	3	8	M 20	22
250	395	273	276.2	26	26	26	350	68	292	6.3	12	16	320	3	12	M 20	22
300	445	323.9	327.6	26	26	26	400	68	344	7.1	12	16	370	4	12	M 20	22
350	505	355.6	359.7	26	26	28	460	68	385	7.1	12	16	430	4	16	M 20	22
400	565	406.4	411	26	26	32	515	72	440	7.1	12	16	482	4	16	M 24	26
450	615	457	462.5	28	-	38	565	72	488	7.1	12	16	532	4	20	M 24	26
500	670	508	513.6	28	28	38	620	75	542	7.1	12	16	585	4	20	M 24	26
600	780	610	-	28	-	-	725	80	642	7.1	12	18	685	5	20	M 27	30
700	895	711	-	30	-	-	840	80	745	8	12	18	800	5	24	M 27	30
800	1015	813	-	32	-	-	960	90	850	8	12	18	905	5	24	M 30	33
900	1115	914	-	34	-	-	1050	95	950	10	12	20	1005	5	28	M 30	33
1000	1230	1016	-	34	-	-	1160	95	1052	10	16	20	1110	5	28	M 33	36
1200	1455	1220	-	38	-	-	1380	115	1255	11	16	25	1330	5	32	M 36	39
1400	1675	1420	-	42	-	-	1590	120	1460	12	16	25	1535	5	36	M 39	42
1600	1915	1620	-	46	-	-	1920	130	1665	14	16	25	1760	5	40	M 45	48
1800	2115	1820	-	50	-	-	2020	140	1868	15	16	30	1960	5	44	M 45	48
2000	2325	2020	-	54	-	-	2230	150	2072	16	16	30	2170	5	48	M 45	48
2200	2550	2220	-	58	-	-	2440	160	2275	18	18	35	2370	6	52	M 52	56
2400	2760	2420	-	62	-	-	2650	170	2478	20	18	35	2570	6	56	M 52	56
2600	2960	2620	-	66	-	-	2850	180	2680	22	18	40	2780	6	60	M 52	56
2800	3180	2820	-	70	-	-	3070	190	2882	22	18	40	3000	6	64	M 52	56
3000	3405	3020	-	75	-	-	3290	200	3085	24	18	45	3210	6	68	M 56	62

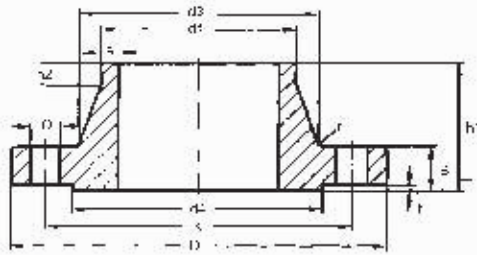

WNRF

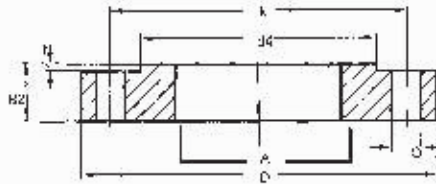

SORF

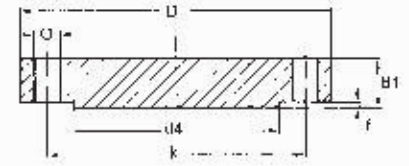

BLRF

DIMENSIONS IN MM OF PN 16 FLANGES

SIZE	D	D1	A	B	B1	B2	k	h1	d3	s	r	h2	d4	f	No	Size	O
	O.D	NECK OD	ID	thk 2633	thk 2527	thk	PCD	wir'		Neck			2F 2633	# thk	cl holes	BOL	Idc
			SORF	WNRF	BLRF	SORF		height					WNRF				D.A
10	90	17.2	17.7	14	14	14	60	35	28	1.8	4	6	40	2	4	M 12	14
15	95	21.3	22	14	14	14	65	35	32	2	4	6	45	2	4	M 12	14
20	105	26.9	27.6	16	16	16	75	38	40	2.3	4	6	58	2	4	M 12	14
25	115	33.7	34.4	16	16	16	85	38	45	2.6	4	6	68	2	4	M 12	14
32	140	42.1	43.1	16	16	16	100	40	56	2.6	6	6	78	2	4	M 16	18
40	150	48.3	49	16	16	16	110	42	64	2.6	6	7	88	3	4	M 16	18
50	165	60.3	61.1	18	18	18	125	45	75	2.9	6	8	102	3	4	M 16	18
65	185	76.1	77.1	18	18	18	145	45	90	2.9	6	10	122	3	4	M 16	18
80	200	88.9	90.3	20	20	20	160	50	105	3.2	8	10	138	3	8	M 16	18
100	220	114.3	115.9	20	20	20	180	52	131	3.6	8	12	158	3	8	M 16	18
125	250	139.5	141.6	22	22	22	210	55	156	4	8	12	188	3	8	M 16	18
150	285	168.3	170.5	22	22	22	240	55	184	4.5	10	12	212	3	8	M 20	22
175	315	193.7	196.1	24	24	24	270	60	210	5.4	10	12	242	3	8	M 20	22
200	340	219.1	221.8	24	24	24	295	62	235	5.9	10	16	268	3	8	M 20	22
250	405	273	276.2	26	26	26	355	70	292	6.3	12	16	320	3	12	M 24	26
300	460	323.9	327.6	28	28	28	410	78	344	7.1	12	16	378	4	12	M 24	26
350	520	355.6	359.7	30	30	30	470	82	390	8	12	16	438	4	16	M 24	26
400	580	406.4	411	32	32	32	525	85	445	8	12	16	490	4	16	M 27	30
450	640	457	462.5	34	-	34	585	85	490	8	12	16	550	4	20	M 27	30
500	715	508	513.6	34	34	34	650	90	548	8	12	16	610	4	20	M 30	33
600	840	610		36	-	-	770	95	652	8.8	12	18	725	5	20	M 33	36
700	910	711		36	-	-	840	100	755	8.8	12	18	795	5	24	M 33	36
800	1025	813		38	-	-	950	105	855	10	12	20	900	5	24	M 36	39
900	1125	914		40	-	-	1050	110	955	10	12	20	1000	5	28	M 36	39
1000	1255	1016		42	-	-	1170	120	1058	10	16	22	1115	5	28	M 39	42
1200	1485	1220		48	-	-	1390	130	1262	13	16	30	1330	5	32	M 45	48
1400	1685	1420		52	-	-	1590	145	1465	14	16	30	1530	5	36	M 45	48
1600	1930	1620		58	-	-	1820	160	1688	16	16	35	1750	5	40	M 52	56
1800	2130	1820		62	-	-	2020	170	1870	18	16	35	1950	5	44	M 52	56
2000	2345	2020		66	-	-	2230	180	2072	20	16	40	2150	5	48	M 56	62

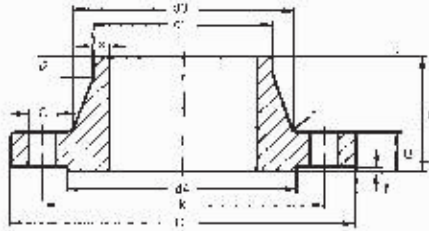

WNRF

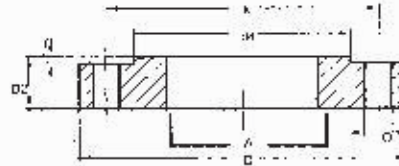

SORF

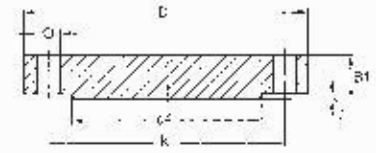

BLRF

DIMENSIONS IN MM OF PN 25 FLANGES

SIZE	D	D1	A	B	B1	B2	k	h1	d3	s	r	h2	d4	f	No. of Holes	Size	O
	O.D	W.C.D	ID	th. 2034	th. 2527	th	FCD	wrnf height		th. 2034	th. 2527		RF 2034	RF th		BOLI	Hole
				WNRF	BLRF	SORF				WNRF			WNRF				
10	90	17.2	17.7	16	16	16	60	35	28	1.8	4	6	40	2	4	M 12	14
15	95	21.3	22	16	16	16	65	38	32	2	4	6	45	2	4	M 12	14
20	105	26.9	27.6	18	18	18	75	40	40	2.3	4	6	58	2	4	M 12	14
25	115	33.7	34.4	18	18	18	85	40	46	2.6	4	6	68	2	4	M 12	14
32	140	42.4	43.1	18	18	18	100	42	56	2.6	6	6	78	2	4	M 16	18
40	150	48.3	49	18	18	18	110	45	64	2.6	6	7	88	3	4	M 16	18
50	165	60.3	61.1	20	20	20	125	48	75	2.9	6	8	102	3	4	M 16	18
65	185	76.1	77.1	22	22	22	145	52	90	2.9	6	10	122	3	8	M 16	18
80	200	88.9	90.3	24	24	24	160	58	105	3.2	8	12	136	3	8	M 16	18
100	235	114.3	115.9	24	24	24	190	65	134	3.6	8	12	162	3	8	M 20	22
125	270	139.5	141.6	26	26	26	220	68	162	4	8	12	188	3	8	M 24	26
150	300	168.3	170.5	28	28	28	250	75	192	4.5	10	12	218	3	8	M 24	26
175	330	193.7	196.1	28	28	28	280	75	218	5.6	10	15	248	3	12	M 24	26
200	360	219.1	221.8	30	30	30	310	80	244	6.3	10	16	278	3	12	M 24	26
250	425	273	276.2	32	32	32	370	88	298	7.1	12	18	335	3	12	M 27	30
300	485	323.9	327.6	34	34	34	430	92	352	8	12	18	395	4	16	M 27	30
350	555	355.6	359.7	38	38	38	490	100	398	8	12	20	450	4	16	M 30	33
400	620	408.4	411	40	40	40	550	110	452	8.8	12	20	505	4	16	M 33	36
450	670	457	462.5	42	-	42	600	110	500	8.8	12	20	560	4	20	M 33	36
500	730	508	513.6	44	45	44	660	125	558	10	12	20	615	4	20	M 33	36
600	845	610	-	46	-	-	770	125	660	11	12	20	720	5	20	M 36	39
700	960	711	-	46	-	-	875	125	760	13	20	24	820	5	24	M 39	42
800	1085	813	-	50	-	-	990	135	865	14	22	24	930	5	24	M 45	48
900	1185	914	-	54	-	-	1090	145	968	16	24	28	1030	5	28	M 45	48
1000	1320	1016	-	58	-	-	1210	155	1070	18	24	28	1140	5	28	M 52	56

DIMENSIONS IN MM OF PN 40 FLANGES

SIZE	D	D1	A	B	B1	B2	k	h1	d3	s	r	h2	d4	f	No	Size	O
	O.D	W.C.D	ID	th. 2034	th. 2527	th	FCD	wrnf height		th. 2034	th. 2527		RF 2034	RF th	of Holes	BOLI	Hole
				WNRF	BLRF	SORF				WNRF			WNRF				
10	90	17.2	17.7	16	16	16	60	35	28	1.8	4	6	40	2	4	M 12	14
15	95	21.3	22	16	16	16	65	38	32	2	4	6	45	2	4	M 12	14
20	105	26.9	27.6	18	18	18	75	40	40	2.3	4	6	58	2	4	M 12	14
25	115	33.7	34.4	18	18	18	85	40	46	2.6	4	6	68	2	4	M 12	14
32	140	42.4	43.1	18	18	18	100	42	56	2.6	6	6	78	2	4	M 16	18
40	150	48.3	49	18	18	18	110	45	64	2.6	6	7	88	3	4	M 16	18
50	165	60.3	61.1	20	20	20	125	48	75	2.9	6	8	102	3	4	M 16	18
65	185	76.1	77.1	22	22	22	145	52	90	2.9	6	10	122	3	8	M 16	18
80	200	88.9	90.3	24	24	24	160	58	105	3.2	8	12	136	3	8	M 16	18
100	235	114.3	115.9	24	24	24	190	65	134	3.6	8	12	162	3	8	M 20	22
125	270	139.5	141.6	26	26	26	220	68	162	4	8	12	188	3	8	M 24	26
150	300	168.3	170.5	28	28	28	250	75	192	4.5	10	12	218	3	8	M 24	26
175	330	193.7	196.1	32	32	32	295	82	218	5.6	10	15	260	3	12	M 27	30
200	375	219.1	221.8	34	34	34	320	88	244	6.3	10	16	285	3	12	M 27	30
250	450	273	276.2	38	38	38	385	105	306	7.1	12	18	345	3	12	M 30	33
300	515	323.9	327.6	42	42	42	450	115	362	8	12	18	410	4	16	M 30	33
350	580	355.6	359.7	46	46	46	510	125	408	8.8	12	20	465	4	16	M 33	36
400	660	408.4	411	50	50	50	585	135	462	11	12	20	535	4	16	M 36	39
450	685	457	462.5	50	50	50	610	135	500	12.5	12	20	560	4	20	M 36	39
500	755	508	513.6	52	52	52	670	140	562	14.2	12	20	615	4	20	M 39	42



Dimensions of Long Radius Elbows

Nominal Diameter	Cut Side Diameter	Center to end 45°		Center to Center	90° L/R Elbow Approx Weight					
		NPS	DN		Sch-5	Sch-10	Sch-20	Sch-30	Sch-40	
1/2	15	18 218	38	38	76	0.04 0.05	0.05 0.06	0.06 0.07	0.08 0.08	0.08 0.10
3/4	20	25 26.7	38	19	76	0.08 0.06	0.07 0.08	0.08 0.09	0.09 0.10	0.13 0.13
1	25	32 33.4	38	38	76	0.06 0.08	0.08 0.13	0.09 0.135	0.10 0.15	0.13 0.19
1 1/4	32	38 42.2	48	48	95	0.11 0.13	0.18 0.25	0.21 0.23	0.23 0.26	0.31 0.35
1 1/2	40	45 48.3	57	57	114	0.16 0.17	0.26 0.28	0.30 0.61	0.34 0.66	0.44 0.90
2	50	57 60.3	76	76	152	0.25 0.29	0.24 0.46	0.57 0.61	0.62 0.66	0.85 0.90
2 1/2	65	75 76.1	95	44	190	0.55 0.57	0.80 0.83	0.97 1.10	1.35 1.30	1.72 1.80
3	80	89	114	114	229	0.80	1.17	1.15	2.04	2.86
3 1/2	90	101.6	133	133	267	1.08	1.17	1.15	2.04	2.86
4	100	108 114.3	152	84	305	1.31 1.39	1.91 2.03	2.65 2.87	3.54 3.76	5.13 5.46
5	125	133 141.3 139.7	190	190	381	2.68 2.82 2.87	3.24 3.45 3.41	4.81 5.12 5.06	6.16 6.54 6.47	8.71 9.26 9.14
6	150	159 168.3	229	229	457	3.85 4.10	4.89 4.96	6.97 7.24	9.68 9.95	14.4 15
8	200	219 218.3	305	305	610	7.15 7.05	9.65 9.53	16.1 15.9	20.4 20.1	31 30.5
10	250	273 267.4	381	381	762	13.7 13.2	16.7 16.3	25.8 24.6	38.2 35.4	57.2 56.2
12	300	325 323.9 318.5	457	457	914	23.0 22.8 22.3	28.1 28 25.3	36.1 36 35.3	55.7 55.5 56.1	95.2 94.8 92.7
14	350	377 355.8	533	533	1067	30.8 29.0	36.9 34.7	30.2 56.7	83.1 78.2	147 138
16	400	426 406.4 508	610	610	1219	41.8 39.9 71.48	47.7 45.5 82.72	78 74.3 118.37	122 116 141.17	211 201 186.94
18	450	478 457.2	686	686	1372	53.11 50.78	60.52 57.86	100.62 96.14	199.44 114.14	158.10 151.03
22	500	559 508	838	343	1524	86.58 71.48	100.21 82.72	144.06 118.87	171.14 141.17	228.75 186.94
22	550	559	838	343	1876	86.58	100.21	144.06	171.14	228.75
24	600	630 610	914	914	1829	123.32 119.37	141.16 136.84	177.37 171.87	210.78 203.98	278.45 270.40

Dimensions of Short Radius Elbows

Nominal size	DN	Out Side Diameter	Center to center (O)	Center to center (O)	90° S/R Elbow Approx Weight (Kg)				
					Sch-5	Sch-10	Sch-20	Sch-30	Sch-40
1	25	33.5	50.8	41.1	0.05	0.08	0.09	0.1	0.13
1 1/4	32	42.2	63.5	52.3	0.08	0.14	0.16	0.17	0.23
1 1/2	40	48.3	76.2	62	0.11	0.19	0.21	0.24	0.33
2	50	60.5	101.6	81	0.19	0.32	0.41	0.44	0.8
2 1/2	65	73.2	127	100.1	0.39 0.37	0.55 0.53	0.65 0.62	0.91 0.87	1.21 1.15
3	80	88.9	152.4	120.7	0.54	0.78	1.01	1.36	1.84
3 1/2	90	101.6	177.8	139.7	0.73	1.04	1.36	1.91	2.62
4	100	114.3	203.2	158.8	0.89 0.91	1.27 1.35	1.65 1.75	2.44 2.58	3.39 3.59
5	125	141.2	254	196.9	1.79 1.90 1.88	2.18 2.32 2.50	3.17 3.38 3.54	4.10 4.37 4.32	5.83 6.22 6.14
6	150	168.1	304.8	236.5	2.72 2.57 2.66	3.32 3.15 3.26	4.84 4.56 4.74	6.79 6.40 6.65	10.23 9.63 10.02
8	200	218.9	406.4	312.7	4.71 4.68	6.41 6.32	10.61 10.46	13.65 13.46	20.74 20.44
10	250	273.1	508	390.7	9.08 8.88	11.16 10.92	16.54 16.29	24.22 23.76	32.75 32.04
12	300	323.9	609.6	466.9	15.12 15.07 14.79	17.42 17.36 17.04	23.88 23.80 23.36	35.78 35.64 34.79	47.18 47.10 46.12
14	350	355.6	711.2	533.4	20.51 19.33	24.70 23.28	40.99 38.81	48.62 45.79	64.24 60.48
16	400	406.4	812.8	609.6	27.98 26.68	31.88 30.40	52.95 50.47	62.81 59.89	83.11 79.17
18	450	457.2	914.4	685.8	35.38 33.83	40.32 38.54	67.01 64.05	79.57 76.04	105.32 100.61
20	500	508	1016	762	-	-	-	-	-
22	550	558.8	1117.6	838.2	-	-	-	-	-
24	600	609.6	1219.2	914.4	-	-	-	-	-



ANSI B 36.19 Stainless Steel Pipe Dimension in MM & Weight Per Kg.

Nominal Pipe size	Outside Diameter	Schedule 5 S		Schedule 10 S		Schedule 20 S		Schedule 40 S		Schedule 80 S		Schedule 160 S		XXS		
		WT. mm	Wt. mm	WT. mm	Wt. mm	WT. mm	Wt. mm	WT. mm	Wt. mm	WT. mm	Wt. mm	WT. mm	WT. mm	WT. mm	WT. mm	WT. mm
3	1/8	10.3	1.2	0.260	1.24	0.280	1.5	0.33	1.73	0.370	2.41	0.475	-	-	-	-
6	1/4	13.7	1.2	0.370	1.65	0.498	2.00	0.58	2.24	0.643	3.02	0.808	-	-	-	-
10	3/8	17.1	1.2	0.470	1.65	0.640	2.00	0.74	2.31	0.857	3.20	1.116	-	-	-	-
15	1/2	21.3	1.65	0.812	2.11	1.014	2.90	1.07	2.77	1.286	3.73	1.642	4.78	1.94	7.67	2.55
20	3/4	26.7	1.65	1.032	2.11	1.300	2.55	1.57	2.87	1.708	3.91	2.225	5.56	2.90	7.82	3.64
25	1	33.4	1.65	1.310	2.77	2.121	2.55	1.94	3.38	2.537	4.55	3.282	6.35	4.24	9.09	5.45
32	1 1/4	42.2	1.65	1.671	2.77	2.728	3.00	2.90	3.56	3.435	4.85	4.524	6.35	5.61	9.70	7.77
40	1 1/2	48.3	1.65	1.923	2.77	3.150	3.00	3.35	3.68	4.101	5.08	5.484	7.14	7.25	10.15	9.55
50	2	60.3	1.65	2.421	2.77	3.986	3.00	4.24	3.91	5.515	5.54	7.588	8.74	11.11	11.07	13.44
65	2 1/2	73.0	2.11	3.741	3.05	5.336	4.00	6.81	5.16	8.756	7.01	11.570	9.53	14.91	14.02	20.39
80	3	88.9	2.11	4.578	3.05	6.546	4.00	8.37	5.49	11.448	7.82	15.484	11.11	21.30	15.24	27.68
100	4	114.3	2.11	5.918	3.05	8.483	4.50	12.18	6.02	16.296	8.58	22.628	13.49	33.54	17.12	41.03
125	5	141.3	2.77	9.593	3.40	11.721	5.00	18.80	6.55	22.065	9.53	31.364	15.88	49.11	19.05	57.43
150	6	168.3	2.77	11.461	3.40	14.014	6.35	25.36	7.11	28.648	10.97	43.142	18.25	67.53	21.95	79.22
200	8	219.1	2.77	14.979	3.75	20.240	6.35	33.31	8.16	43.129	12.7	65.526	23.01	111.27	22.23	107.92
250	10	273.1	3.40	22.920	4.19	28.163	6.35	41.77	9.27	61.131	12.7	82.661	28.58	172.33	25.40	155.15
300	12	323.8	3.96	31.669	4.57	36.477	6.35	49.7	9.53	74.810	12.7	98.790	33.32	238.08	25.40	186.50
350	14	355.0	3.96	34.340	4.78	41.923	7.92	67.90	11.13	95.84	19.5	160.28				
400	16	406.4	4.19	41.560	4.78	47.993	7.92	77.82	12.7	124.99						
450	18	457.2	4.19	46.810	4.78	54.064	7.92	87.74	14.27	157.26						
500	20	508.0	4.78	59.310	5.54	69.590	9.53	117.14	15.09	185.95						
600	24	610.0	5.54	82.570	6.35	94.520	9.53	141.11	17.48	255.41						

Formula: Pipe Weight Kg / Mtr = OD - Thick x Thick x 0.02466 = Kg Per Mtr.

Chemical Composition & Mechanical Properties of S.S. Pipe as per ASTM A 312

Grade	Chemical Composition %									Mechanical Properties, min						
	C	Si	Mn	P	S	N	Cr	Mo	Other	Tensile Strength min. Ksi (Mpa)	Yield Point Ksi (Mpa)	Elongation % (G.L., 2in or 1min)			Hardness Test Max	
	Max	Max	Max	Max	Max							Full Section	Strip Specimen	Round Specimen	Brinell	Rockwell
304	0.08	1.00	2.00	0.045	0.030	8.00-11.0	18.0-20.0	-	-	75(515)	30(205)	35	35.56T + 17.50	28	192	B 90
304L	0.035	1.00	2.00	0.045	0.030	8.00-13.0	18.0-20.0	-	-	70(485)	25(170)	35	35.56T + 17.50	28	192	B 90
304H	0.04-0.10	1.00	2.00	0.045	0.030	8.00-11.0	18.0-20.0	-	-	75(515)	30(205)	35	35.56T + 17.50	28	192	B 90
316	0.08	1.00	2.00	0.045	0.030	11.0-14.0	16.0-18.0	2.0/3.0	-	75(515)	30(205)	35	35.56T + 17.50	28	192	B 90
316L	0.035	1.00	2.00	0.045	0.030	10.0-14.0	14.0-18.0	2.0/3.0	-	70(485)	25(170)	35	35.56T + 17.50	28	192	B 90
316H	0.04-0.10	1.00	2.00	0.045	0.030	11.0-14.0	16.0-18.0	2.0/3.0	-	75(515)	30(205)	35	35.56T + 17.50	28	192	B 90
316Ti	0.08	0.75	2.00	0.045	0.030	10.0-12.0	16.0-18.0	2.0/3.0	Ti&C% <0.70	75(515)	30(205)	35	35.56T + 17.50	28	192	B 90
317L	0.035	1.00	2.00	0.045	0.030	11.0-15.0	18.0-20.0	3.0/4.0	-	75(515)	30(205)	35	35.56T + 17.50	28	192	B 90
309S	0.08	1.00	2.00	0.045	0.030	12.0-15.0	22.0-24.0	0.75	-	75(515)	30(205)	35	35.56T + 17.50	28	192	B 90
310S	0.08	1.00	2.00	0.045	0.030	19.0-22.0	24.0-26.0	0.75	-	75(515)	30(205)	35	35.56T + 17.50	28	192	B 90
310H	0.04-0.10	1.00	2.00	0.045	0.030	19.0-22.0	24.0-26.0	-	-	75(515)	30(205)	35	35.56T + 17.50	28	192	B 90
321	0.08	1.00	2.00	0.045	0.030	9.0-12.0	17.0-19.0	-	Ti&C% <0.70	75(515)	30(205)	35	35.56T + 17.50	28	192	B 90
312H	0.04-0.10	1.00	2.00	0.045	0.030	9.0-12.0	17.0-19.0	-	Ti&C% <0.60	75(515)	30(205)	35	35.56T	28	192	B 90
347	0.08	1.00	2.00	0.045	0.030	9.0-13.0	17.0-19.0	-	Nb/Ta: 10xC% <1%	75(515)	30(205)	35	35.56T + 17.50	28	192	B 90
347H	0.04-0.10	1.00	2.00	0.045	0.030	9.0-13.0	17.0-19.0	-	Nb/Ta: 8xC% <10%	75(515)	30(205)	35	35.56T + 17.50	28	192	B 90



Application Industries



Power House



Steel Plant



Offshore Platform



Chemical Industries



Petrochemical Industries

FORMULA OF CALCULATING WEIGHT

- 1) **WEIGHT OF S. S. PIPE**
 $O.D. (mm) - W. Thick (mm) \times W. Thick (mm) \times 0.0248 = Wt. Per Mtr.$
 $O.D. (mm) - W. Thick (mm) \times W. Thick (mm) \times 0.00756 = Wt. Per Feet$
- 2) **WEIGHT OF S. S. ROUND BAR**
 $DIA (mm) \times DIA (mm) \times 0.00623 = Wt. Per Mtr.$
 $DIA (mm) \times DIA (mm) \times 0.0019 = Wt. Per Feet$
- 3) **WEIGHT OF S. S. SQUARE BAR**
 $DIA (mm) \times DIA (mm) \times 0.00788 = Wt. Per Mtr.$
 $DIA (mm) \times DIA (mm) \times 0.0024 = Wt. Per Feet$
- 4) **WEIGHT OF S. S. HEXAGONAL BAR**
 $DIA (mm) \times DIA (mm) \times 0.00680 = Wt. Per Mtr.$
 $DIA (mm) \times DIA (mm) \times 0.002072 = Wt. Per Feet$
- 5) **WEIGHT OF S. S. FLAT BAR**
 $Width (mm) \times Thick (mm) \times 0.00798 = Wt. Per Mtr.$
 $Width (mm) \times Thick (mm) \times 0.00243 = Wt. Per Feet$
- 6) **WEIGHT OF S. S. SHEETS & PLATES**
 $Length (Mtrs) \times Width (Mtrs) \times Thick (mm) \times 8 = Wt. Per PC$
 $Length (Fit) \times Width (Fit) \times Thick (mm) \times 3/4 = Wt. Per PC$
- 7) **WEIGHT OF S. S. CIRCLE**
 $DIA (mm) \times DIA (mm) \times Thick (mm) \div 160 = Gms. PC$
 $DIA (mm) \times DIA (mm) \times Thick (mm) \times 0.0000063 = Kg. Per PC$
- 8) **WEIGHT OF BRASS PIPE / COPPER PIPE**
 $O.D. (mm) - Thick (mm) \times 0.0260 = Wt. Per Mtr.$
- 9) **WEIGHT OF LEAD PIPE**
 $O. D. (mm) - Wt. (mm) \times Wt. (mm) \times 0.0345 = Wt. Per Mtr.$
- 10) **WEIGHT OF ALUMINIUM PIPE**
 $O. D. (mm) - Thick (mm) \times Thick (mm) \times 0.0083 = Wt. Per Mtr.$
- 11) **WEIGHT OF ALUMINIUM SHEET**
 $Length (Mtr.) \times Width (Mtr.) \times Thick (mm) \times 2.69 = Wt. Per PC$
- 12) **WEIGHT OF CONVERSION OF MTR. TO FEET**
 $Wt. of Mtr. \div 3.2808 = Wt. Per Feet.$

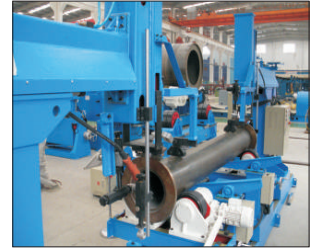

Flange CNC Machine



Fertilizer Plants



Refinery Petrochemical Plant



Port Trusts



Navy Submarine



Gurukrupa Industries

AN ISO 9001 : 2008 CERTIFIED COMPANY

Mfg. & Sp. In : S.S. FLANGES, PIPES, PIPE FITTING & VALVES,
All Types of Industrial Raw Materials & Machinery Parts Sheets, Round Bars,
Pipes & Flates in Series of Copper, Brass, M.S. Aluminium & Welding Rods

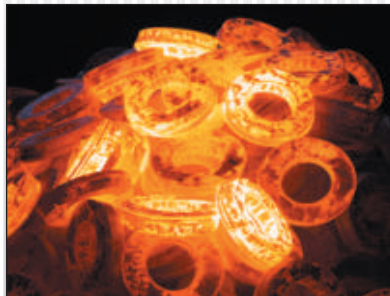
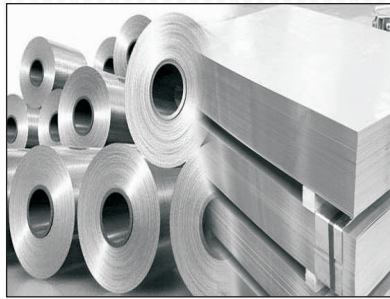

1, Laxmi Estate, Opp. Ajay Shakari Estate, Nr. Keval Kanta, Gujarat Botling Road, Rakhial, Ahmedabad - 23.
Ph.: 079-2273 0683 / 6541 7612

E-mail : gurukrupametal@yahoo.com / gurukrupametal561@gmail.com • Website : www.gurukrupametal.com